

Search Coil Magnetometer Based on Multi-parameter Joint Optimization Design in Ultra Low-Frequency Communication

Chunteng Li¹, Yuzhong Jiang^{1*}, Guanghui Yang¹, and Fangjun Liu²

¹College of Electronic Engineering, Naval University of Engineering, Jiefang Road, Wuhan 430033, China

²Academy of Mathematics and Computer Science, Yunnan Nationalities University, Yuhua Road, Kunming 650031, China

(Received 16 November 2017, Received in final form 18 March 2018, Accepted 24 March 2018)

In order to design a kind of high-sensitive, narrow-band and portable search coil magnetometer, based on the principle of magnetic measuring, an equivalent model of search coil magnetometer with parallel matched capacitor is established. The formula of the induced coil is derived, low-noise integrated operational amplifier is designed and made as the preamplifier circuit of search coil magnetometer. The parameters of the inductive coil based on multi-parameter joint optimization are obtained under consideration of the sensitivity, bandwidth, weight and volume of the inductive coil simultaneously. The search coil magnetometer test is completed in the electromagnetic shielding room. And the result shows that the sensitivity of the designed search coil magnetometer is $40 \text{ fT}/\sqrt{\text{Hz}}$ @80 Hz, under the precondition of guaranteeing the weight, volume and bandwidth, which is basically the same as that of the simulation.

Keywords : Ultra-low frequency, search coil magnetometer, operational amplifier, sensitivity, narrow band, portability

1. Introduction

Search coil magnetometer is a kind of magnetometer based on Faraday's law of electromagnetic induction. Due to its wide frequency range and high sensitivity, it is widely used in the fields of geophysical exploration and through-ground communication [1-3]. However, owing to the limitation of the parameter optimization method and the noise problem of the amplifier in the low frequency range, the search coil magnetometer has been limited to the ultra-low frequency band. With the increasing demand for search coil magnetometer in ultra-low frequency communication, high sensitivity, narrow-band and portable magnetic sensor has become an important research direction.

In view of the optimization of search coil magnetometer, Lukoschus [4] proposed optimization theory for search coil magnetometers. A. Grosz and E. Paperno [5] have designed search coil to minimize thermal noise by optimizing diameters of the ferromagnetic core and winding wire. Yan *et al.* [6] proposed two different optimization method considering given volume and ferromagnetic

core. Coillot *et al.* [7] optimized the magnetometer in aspect of ferromagnetic core. In our optimization system, considering the sensitivity, bandwidth, weight and volume of the inductive coil, the winding diameter, the number of turns and the equivalent diameter of the ferromagnetic core are optimized simultaneously.

2. The Magnetic Sensor Model with Parallel Matched Capacitor

Symbols in this paper are defined in Table 1.

Table 1. Nomenclature.

R_{sc}	Coil resistance	L_{pc}	Coil inductance
C_{sc}	Coil capacitance	C_p	Matched capacitance
C	Total capacitance	G	Gain of preamplifier
N	Number of turns	N_B	demagnetizing factor
μ_r	Relative permeability	μ_{app}	Effective permeability
l	Length of ferromagnetic core	d	Equivalent diameter of ferromagnetic core
q	The ratio of l/d	d_{wins}	Diameter of the coil with insulator
d_w	Diameter of the coil without insulator	β	The ratio of d_{wins}/d_w
l_w	Length of coil	γ	The ratio of l_w/l

©The Korean Magnetism Society. All rights reserved.

*Corresponding author: Tel: +86-15336303763

Fax: +86-15336303763, e-mail: scholarqh@163.com

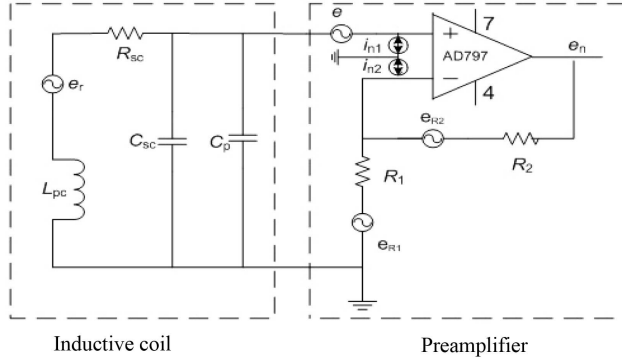

Fig. 1. The basic model of designed magnetic sensor.

Ultra-low frequency communication needs to perform by narrowband search coil magnetometer, narrowband can fully suppress out-of-band interference and improve in-band sensitivity. Aiming at this problem, a kind of high-sensitivity narrow-band search coil magnetometer is designed. By tuning the parallel matching capacitance, the resonant frequency of search coil magnetometer is tuned to the carrier frequency to reduce the bandwidth of the inductive coil so as to suppress out-of-band interference and improve in-band sensitivity.

Search coil magnetometer includes inductive coil and preamplifier, the basic model is shown in Fig. 1. The inductive coil obtains the magnetic field signal and transforms it into voltage signal. The inductive coil can be equivalent to a second-order system model where the inductance L_{pc} , resistance R_{sc} , and capacitance C are composed. The right-hand dashed box is the preamplifier model. Preamplifier noise is mainly converted from 5 parts: current i_{n2} amplified thermal noise through R_1 and R_2 , voltage e amplified thermal noise, current i_{n1} amplified thermal noise by coil impedance Z and thermal noise generated by R_2 .

2.1. Inductive coil optimization design

As the front magnetosensitive part of the search coil magnetometer, inductive coil parameters have a deeply impact on the overall performance of the search coil magnetometer. The resistance of the inductive coil affects the input noise of the amplifier and the measurement accuracy of the search coil magnetometer. The inductance of the inductive coil affects the resonant frequency. Next, under the condition of meeting the bandwidth requirement, the idea of multi-parameter joint optimizing is adopted to improve the sensitivity, making the weight and volume of the magnetic sensor as small as possible for portability. The basic structure of the inductive coil is shown in Fig. 2.

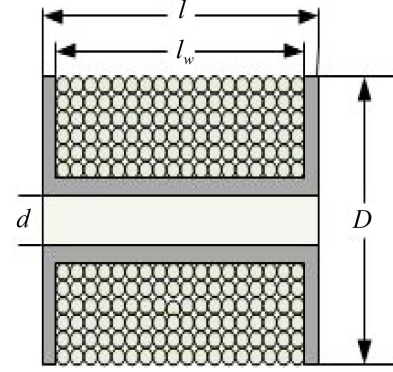

Fig. 2. (Color online) The basic structure of the inductive coil.

Considering only the left part of the model in Fig. 1, the frequency response formula for inductive coil is derived below. According to Faraday's law of electromagnetic induction, the voltage generated by the inductive coil across the matched capacitor is:

$$v(t) = -N \frac{d\Phi}{dt} = \mu_{app} NS \frac{dB}{dt} \quad (1)$$

Where Φ is magnetic flux, S is cross section area of coil, B is magnetic flux density. And μ_{app} can be expressed as [8]:

$$\mu_{app} = \frac{\mu_r}{1 + N_B(\mu_r - 1)} \quad (2)$$

where N_B is demagnetizing factor, which makes the effective permeability smaller than the relative permeability. And it is mainly related to q , which can be expressed as:

$$N_B = \frac{1}{q^2 - 1} \left\{ \frac{q}{2\sqrt{q^2 - 1}} \ln \left(\frac{q + \sqrt{q^2 - 1}}{q - \sqrt{q^2 - 1}} \right) - 1 \right\} \quad (3)$$

The transfer function of the inductive coil is:

$$\frac{V_{out}}{B}(\omega) = \frac{-j\omega\mu_{app}NSG}{1 - \omega^2 L_{pc}C + j\omega R_{sc}C} \quad (4)$$

Equation (4) shows that the amplitude-frequency characteristic of the inductive coil is:

$$H(\omega) = \frac{\omega\mu_{app}NSG}{\sqrt{(1 - \omega^2 L_{pc}C)^2 + (\omega R_{sc}C)^2}} \quad (5)$$

The frequency response of the inductive coil has the largest output at the resonance point $1/2\pi\sqrt{L_{pc}C}$.

2.2. Analysis about q

The ferromagnetic core constitutes the magnetosensitive part of the search coil magnetometer. From (1), the

induced voltage of the inductive coil is mainly determined by N , S and μ_{app} . Therefore, it is possible to increase the induced voltage by increasing the permeability of the ferromagnetic core. In order to obtain larger initial sensitivity, the ferromagnetic core generally selects the magnetic material with relatively high relative permeability μ_r , such as iron-based nanocrystalline alloy. However, because of N_B , the effective permeability of the core is much smaller than relative permeability. From (2), with the help of many simulations, when q is constant, μ_r has a larger value in order to ensure that μ_{app} is constant. For example, when $q = 20$, in order to ensure that μ_{app} is constant, the ferromagnetic core needs to use the soft magnetic material whose relative permeability μ_r is not less than 10^4 and μ_{app} is only 210. Next, the influence of q on N_B and μ_{app} will be discussed. From equations (2) and (3), when μ_r is greater than 5000 and q is less than 50, μ_r has little influence on the μ_{app} . Based on the above analysis, this paper selected iron-based nanocrystalline alloy material with more than 80000 maximum permeability as the ferromagnetic core and set q as 20.

2.3. Multi-parameter joint analysis about inductive coil

The resistance of the inductive coil determines the thermal noise generated by the coil resistance. Therefore, the resistance should be considered in the coil design. The following will derive the resistance of the inductive coil in detail.

According to Fig. 2, the equivalent diameter of ferromagnetic core d is $\sqrt{4ah/\pi}$, where a and h represent the width and the height of ferromagnetic core respectively, then the width and height of k -layer winding are:

$$a_k = a + (2k - 1)d_{wins} \quad h_k = h + (2k - 1)d_{wins} \quad (6)$$

The length L_k of k -th layer winding is:

$$L_k = \frac{2\gamma l}{d_{wins}} [a + h + 2(2k - 1)d_{wins}] \quad (7)$$

Therefore, the total length L of winding is:

$$L = L_1 + L_2 + \dots + L_k = 2N(a + h) + \frac{4N^2\beta^2 d_w^2}{\gamma l} \quad (8)$$

According to $R = \rho \times L/S$, where ρ is resistivity of copper, the equivalent resistance is:

$$\begin{aligned} R_{sc} = f(N, d, d_w) &= 8N\rho \frac{(a+h)\gamma l + 2N\beta^2 d_w^2}{\pi d_w^2 \gamma l} \\ &= 4N\rho \frac{\pi\gamma q d^2 + 4N\beta^2 d_w^2}{\pi d_w^2 \gamma dq} \end{aligned} \quad (9)$$

The equivalent inductance of the coil is [9]:

$$L_{pc} = f(N, d) = \frac{N^2 \mu_0 \mu_{app} ah}{l} \gamma^{-\frac{3}{5}} = \frac{N^2 \mu_0 \mu_{app} d}{4q} \gamma^{-\frac{3}{5}} \quad (10)$$

where μ_0 represents the vacuum permeability.

Weight of search coil magnetometer mainly consists of two parts, one part is the ferromagnetic core, the other part is the winding. Given that the weight of outer layer insulation material is relatively small, it is neglected. The weight of the core and coil is respectively expressed as:

$$\begin{aligned} W_{core} &= \rho_c ah\gamma l \quad W_{coil} = \rho_{co} \pi \left(\frac{d_w^2}{2} \right) L \\ &= \rho_{co} \left[\frac{\pi N d_w^2 (a+h)}{2} + \frac{\pi N^2 \beta^2 d_w^4}{\gamma l} \right] \end{aligned} \quad (11)$$

Where ρ_c is the density of ferromagnetic core, and ρ_{co} is the density of copper. Therefore, according to (8), the total weight of the inductive coil W_{total} is:

$$W_{total} = f(N, d, d_w) = \rho_c \frac{\pi d^2}{4} + \rho_{co} \pi N d_w^2 \left(\frac{\pi d}{4} + \frac{N\beta^2 d_w^2}{\gamma dq} \right) \quad (12)$$

When the number of turns N , the winding layer p is $N\beta d_w / (\gamma l)$, the width and height are increased by a_i and h_i respectively. Therefore, the inductive coil volume V is:

$$V = f(N, d, d_w) = \left(\frac{4N^2 \beta^4 d_w^4}{\gamma^2 d^2 q^2} + \pi q \frac{N\beta^2 d_w^2}{\gamma} + \pi \frac{d^2}{4} \right) \gamma dq \quad (13)$$

By analyzing the equivalent circuit of the search coil magnetometer in Fig. 1, the equivalent input magnetic noise mainly consists of two parts: the equivalent input magnetic noise of the preamplifier and the thermal noise generated by inductive coil. The thermal noise generated by the inductive coil [10] is:

$$|B_{nrsc}| = \frac{\sqrt{4kTR_{sc}}}{|j2\pi f \mu_{app} NS|} \quad (14)$$

Where k is the Boltzmann constant, $k = 1.38 \times 10^{-23} \text{ J/K}$, and T is the thermodynamic temperature of the resistance in the model in **K**.

The equivalent input magnetic noise of the preamplifier includes the equivalent magnetic noise of the input voltage B_{nvi} and the input current B_{nii} . The equation is respectively expressed as:

$$\begin{aligned} |B_{nvi}| &= \frac{|1 - (2\pi f)^2 L_{pc} C + j2\pi f R_{sc} C| |e|}{|j2\pi f \mu_{app} NS|} \\ |B_{nii}| &= \frac{|R_{sc} + j2\pi f L_{pc}| |i_n|}{|j2\pi f \mu_{app} NS|} \end{aligned} \quad (15)$$

Where e and i_n are input current and voltage of pre-amplifier respectively. From (14) and (15), the equivalent input magnetic noise (sensitivity) B_{st} of the search coil magnetometer can be expressed as:

$$B_{st}(f) = \sqrt{|B_{nrsc}|^2 + |B_{nvi}|^2 + |B_{mi}|^2} \quad (16)$$

Assuming that 3dB bandwidth of the search coil magnetometer is $2\Delta f$, the equation is:

$$\frac{V_{out}(f_r)}{V_{out}(f_r - \Delta f)} = \sqrt{2} \quad (17)$$

Equation (17) is simplified by equation (1) and (4), 3dB bandwidth is:

$$2\Delta f = f(N, d, d_w) = 2f_r + \frac{R_{sc}}{2\pi L_{pc}} - \sqrt{4f_r^2 + \left(\frac{R_{sc}}{2\pi L_{pc}}\right)^2} \quad (18)$$

From the reference [10], the magnetic flux density at the center is the highest, the sensitivity is optimal, and it is reduced to 10 % of the center at the ends. Therefore, in order to avoid the edge effect, the length of the coil is shorter than the length of the core. On the other hand, the coil length can not be too short. In commercialized products, the coil length generally accounts for 50 %-90 % of ferromagnetic core. Therefore, this paper selected $\gamma = l_w/l = 0.6$. The capacitance is in parallel by 220 μF , 10 μF , 10 μF , β set as 1.05, the input voltage and the input current noise density are respectively $e = 1.04 \text{ nV}/\sqrt{\text{Hz}}$, $i_n = 2.65 \text{ fA}/\sqrt{\text{Hz}}$. According to the equations (12), (13), (16) and (18), considering the total weight, the volume, the sensitivity and the 3dB bandwidth of the search coil magnetometer simultaneously, the constraint conditions of above factors is expressed in (19). And the range and

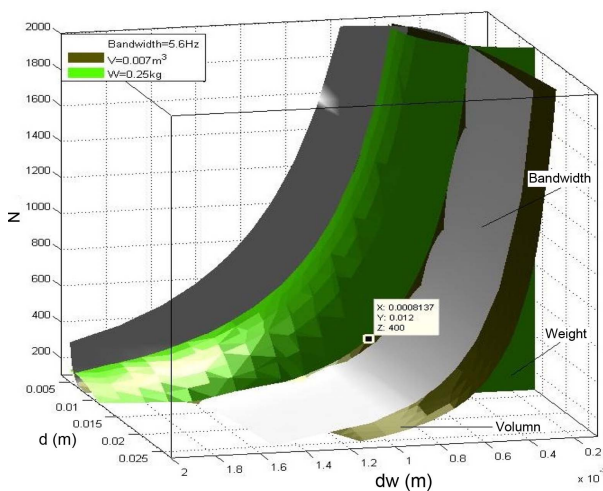

Fig. 3. (Color online) The result of multi-parameter joint optimization about the inductive coil.



Fig. 4. The inductive coil produced.

corresponding increment of three arguments also are expressed in (19). After a large number of simulations, from the engineering application point of view, the total weight is set at 0.25 Kg, the volume is set at 0.007 m^3 , the bandwidth is set at 5.6 Hz, at this time the range of arguments chosen is rather wide. Finally, the optimized result is shown in Fig. 3.

$$\begin{cases} N \in [100, 2000] (\Delta N = 100) \\ d \in [0.005, 0.025] (\Delta d = 0.001) \\ d_w \in [0.0001, 0.002] (\Delta d_w = 0.001) \end{cases} \begin{cases} W_{total} \leq 0.5 \text{ kg} \\ V \leq 0.01 \text{ m}^3 \\ B_{st} \leq 50 \text{ fT}/\sqrt{\text{Hz}} \\ 2\Delta f \leq 6 \text{ Hz} \end{cases} \quad (19)$$

From Fig. 3, the number of turns selected is 400, the equivalent diameter of the core is 0.012 m, winding diameter is 0.0008137 m, therefore, the resonant frequency is 80 Hz by equation $1/2p\sqrt{L_{pc}C}$, the magnetic sensor sensitivity is 33.21 $\text{fT}/\sqrt{\text{Hz}}$ @80 Hz, which meets the sensitivity requirement. The volume and weight of the coil are easy to carry and use. The inductive coil produced is shown in Fig. 4, and the value of winding diameter in the manufacture process of magnetic antennas adopts 0.0008 m.

3. Preamplifier

The right-hand dashed box in Fig. 1 is the noise model of the preamplifier, this paper chooses AD797 as the preamplifier. The amplifier was designed in software called Candence and made into circuit board. The result is shown in Fig. 5 and Fig. 6. The left side of the board is the AD797 amplifier module, R_1 was set as 10 Ω , and R_2 was 490 Ω , AD797 output is filtered by the notch module with 50 Hz, 100 Hz and 150 Hz, the output magnetic sensor signal is received. In this circuit, the choose of the amplifier gain should be paid special attention to void

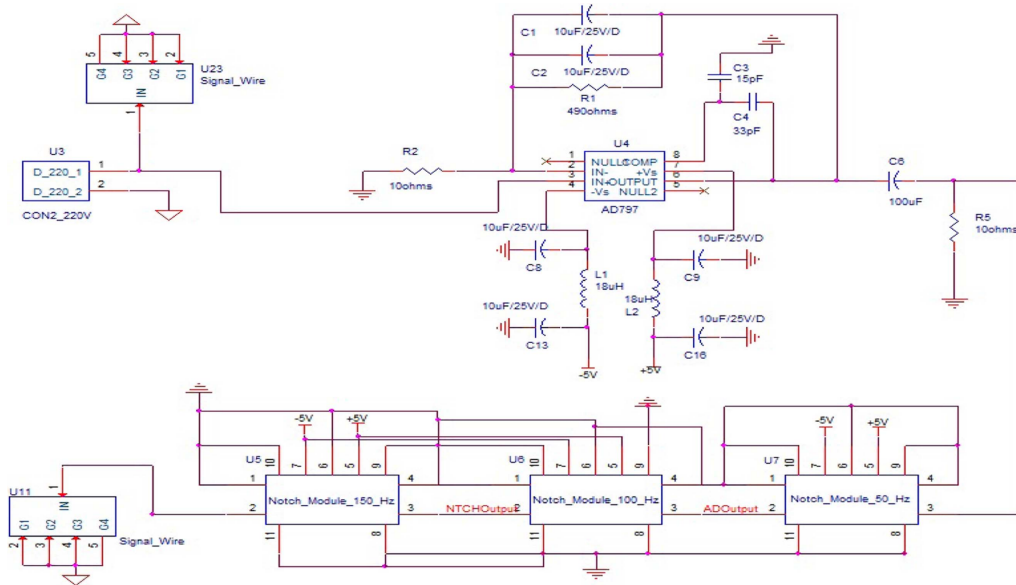

Fig. 5. (Color online) Schematic diagram of interface circuit.

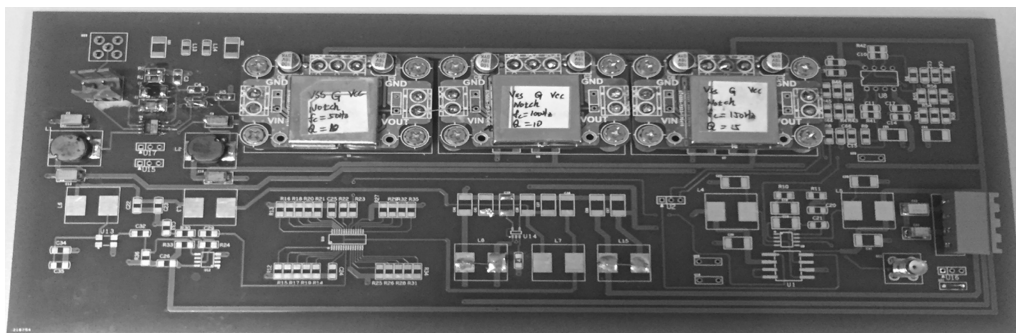

Fig. 6. The hardware circuit structure of search coil magnetometer.

self-excited phenomenon.

4. The Test and Calibration of Search Coil Magnetometer

Search coil magnetometer sensitivity is relatively sensitive to the weak magnetic signal, because of the presence of strong 50 Hz frequency interference, it affects the sensitivity of search coil magnetometer seriously, resulting in inaccurate test result. Therefore, in order to suppress most of the interference effectively and get more accurate result, the test was performed in the electromagnetic shielding room. The size of ferromagnetic core is 300 mm × 10 mm × 15 mm, N is 400, γ is set as 0.6, Agilent 35670A FFT dynamic signal analyzer is selected as acquisition system, rectangular Helmholtz coil with 3 m length, 1.5 m width is used to generate magnetic field. Experiment 1 tests the background noise of the search coil magnetometer, the noise power spectrum is shown in



Fig. 7. Noise power spectrum of background noise.

Fig. 7, the noise power spectrum of the search coil magnetometer at 80 Hz is $2.3 \times 10^{-3} \text{ mV}/\sqrt{\text{Hz}}$.

In Experiment 2, the amplitude-frequency response of the search coil magnetometer was tested. The result is shown in Fig. 8. From Fig. 8, the simulated and measured

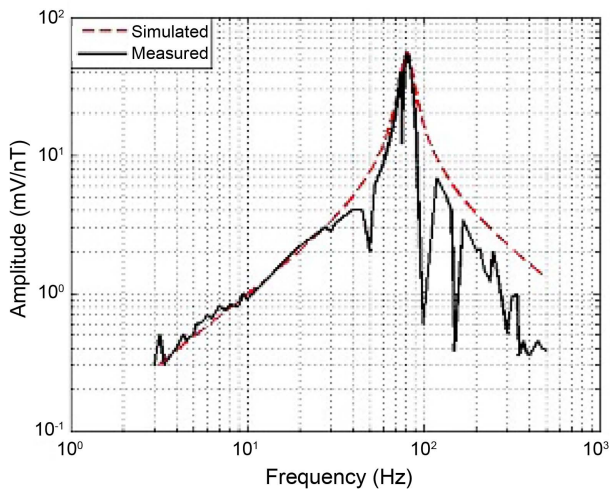

Fig. 8. (Color online) Amplitude-frequency response of search coil magnetometer.

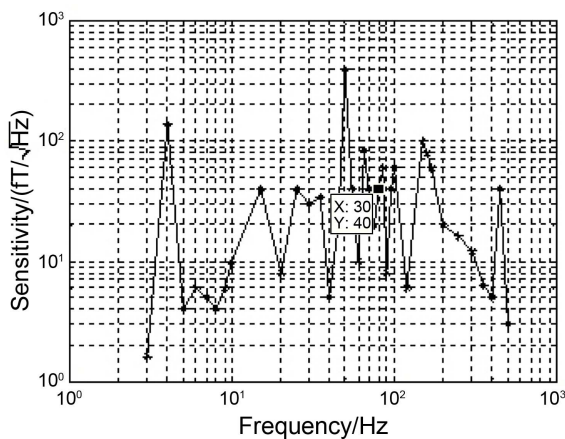

Fig. 9. The sensitivity of search coil magnetometer.

result are basically consistent. Due to the fact that the notch module with 50 Hz, 100 Hz and 150 Hz are connected in the actual analog circuit, the amplitude-frequency response of the search coil magnetometer is different from the simulation obtained at the above three frequency points. Finally, the measured amplitude at 80 Hz is 57 mV/nT.

By the amplitude-frequency response and background noise of search coil magnetometer, the sensitivity can be calculated for each frequency. The sensitivity of search coil magnetometer is equal to the ratio of the noise power spectrum to the amplitude-frequency response at this frequency point. Therefore, the sensitivity of the search

coil magnetometer at different frequency points is shown in Fig. 9. At 80 Hz, the sensitivity of the search coil magnetometer is calibrated at $40.35 \text{ fT}/\sqrt{\text{Hz}} @ 80 \text{ Hz}$.

5. Conclusion

Aiming at the problems encountered in the design of search coil magnetometer in ultra-low-frequency communication, the equivalent coil model with matched capacity in parallel is established. The formulas for calculating the parameters of inductive coil are deduced. The influence of parameters of the inductive coil on its sensitivity provides the theoretical basis for the performance analysis of the search coil magnetometer. The method based on multi-parameter joint optimization is adopted to obtain the optimal parameters of the inductive coil. A kind of low noise integrated operational amplifier as the preamplifier circuit of search coil magnetometer is designed and made. The design of search coil magnetometer is tested in the electromagnetic shielding room. The test result shows that the sensitivity of the designed search coil magnetometer with 0.25 Kg weight, 0.007 m^3 volume and 5.6 Hz bandwidth can reach $40.35 \text{ fT}/\sqrt{\text{Hz}} @ 80 \text{ Hz}$, which is basically the same as the simulated results.

References

- [1] P. Ripka, *Magnetic Sensors and Magnetometers*, Artech House, Boston (2000).
- [2] R. G. Olsen and A. J. Farstad, *IEEE Trans. Geosci. Electron.* **11**, 178 (1973).
- [3] J. Lenz and S. Edelstein, *IEEE Sensors J.* **6**, 631 (2006).
- [4] D. G. Lukoschus, *IEEE Trans. Geosci. Electron.* **17**, 56 (1979).
- [5] A. Grosz and E. Paperno, *IEEE Sensors J.* **12**, 2719 (2012).
- [6] B. Yan, W. Zhu, L. Liu, and K. Liu, *IEEE Trans. Magn.* **49**, 5294 (2013).
- [7] C. Coillot, J. Moutoussamy, M. Boda, and P. Leroy, *J. Sensors Sensor Syst.* **3**, 1 (2014).
- [8] H. C. Seran and P. Fergeau, *Rev. Sci. Instrum.* **76**, 57 (2005).
- [9] C. D. Motchenbacher and J. A. Connelly, *Low-Noise Electronic System Design*, Wiley, New York (1993).
- [10] H. J. Ju, W. H. Zhu, and G. Y. Fang, *Progress in GeoPhysics (in Chinese)* **25**, 1870 (2010).