

Influence of Selected Parameters on the Reseal Instability Mechanism in Magnetic Fluid Seals

Marcin Szczęch*

AGH University of Science and Technology, al. Adama Mickiewicza 30, 30-059 Cracow, Poland

(Received 6 December 2017, Received in final form 24 September 2018, Accepted 21 January 2019)

Magnetic fluid has many technical applications and many new ones are being developed. One of the applications is in magnetic fluid seals. This publication describes the new phenomenon of the magnetic fluid seal reseal mechanism, discovered while carrying out research. This phenomenon is manifested by the pressure oscillation medium being sealed, which results from the instability (cyclic destruction and rebuild of the liquid ring) in the magnetic fluid seal. It occurs in an inhomogeneous magnetic field and, in this case, is caused by the eccentricity of the seal components. In order to study this mechanism, magnetic fluid characterized by different physical properties was selected. Numerical simulations were performed to determine the magnetic field distribution in the seal. Research results showed the possibility of measuring the eccentricity of the magnetic fluid seal elements. Studies have shown that it is possible to determine the displacement of about 0.01 mm.

Keywords : magnetic fluid seals, reseal mechanism, displacement, eccentricity, reseal instability

1. Introduction

Magnetic fluid, in this case Ferrofluid (FF), is a colloidal suspension of ferromagnetic particles in a nonmagnetic carrier fluid. A particle size with a diameter below 10 nm provides a suspension that is stable under the influence of gravity, or a strong magnetic field. Each particle is also coated with a surfactant, which is a compound absorbed on the particle surface and prevents particles from agglomerating. When the magnetic field is applied, the dynamic viscosity of the magnetic fluid changes [1]. Pressure in a fluid is also created and its value depends on the direction and value of the magnetic field [2].

Under certain conditions, interaction between the magnetic field and the magnetic fluid can take place, which might cause the formation of different types of instability. Magnetic fluids exhibit instability like: normal-field instability, Kelvin-Helmholtz instability or labyrinth instability. Instability in the normal direction is formed when the direction of the magnetic field is perpendicular to the free surface of the ferrofluid. A free surface takes the form of a hexagonal or square array of peaks which are in accordance with the directions of the magnetic field lines [3]. Kelvin-Helmholtz

instability refers to the interfacial surface between two fluids with different density [4]. When fluids move in the same direction, but with different velocities, vortices may occur. This instability is considered one of the causes of leaks in the magnetic fluid seal in a water environment [5]. Labyrinth instability is formed when the magnetic field is applied tangent to the ferrofluid placed between closely spaced non-magnetic plates [6].

Ferrofluid has been successfully used in magnetic fluid seals in a rotating motion. This type of seal works on the principle of creating a liquid ring held on a seal stage by a magnetic field. It is characterized by low friction and high reliability and can operate for 10 years and longer. Critical pressure is a characteristic parameter and leaks in this type of seal occur at this value [7]. A characteristic feature is the possibility to rebuild the liquid ring when the pressure drops below a critical value. This is called the self repair or reseal mechanism [8]. When there is a critical pressure recurrence, the value of this pressure is less than the previous time [9]. This is mainly because a certain volume of the fluid is lost from the seal stage [10]. The reseal mechanism is not a well-known phenomenon and there are not many publications on this subject [11]. While carrying out research on this subject, a new mechanism was discovered. Under certain conditions, pressure oscillations of the air being sealed based on cyclic destroying and rebuilding of the magnetic fluid ring may

©The Korean Magnetism Society. All rights reserved.

*Corresponding author: Tel: +48 503080912

Fax: +48 503080912, e-mail: szczech@agh.edu.pl

occur. This phenomenon occurred in the case of a non-homogeneous magnetic field distribution in the ferrofluid. The publication describes the influence of selected parameters on this phenomenon, such as: the magnetic field value, ferrofluid volume, linear velocity of the seal and some physical properties of the ferrofluid.

2. Magnetic Fluid Seal

The magnetic fluid seal used in the studies is shown in Fig. 1. The source of the magnetic field is a permanent magnet (pos. 4) axially polarized. The main elements are magnetic pole pieces (pos. 3a and 3b) and the bushing (pos. 5) with one seal stage (pos. 7). The bushing is mounted on a rotary shaft (pos. 6). These elements are made of materials with ferromagnetic properties. The magnetic fluid (pos. 8) is applied on the seal stage (pos. 10). In this case, a trapezoidal stage shape was selected. This shape is characterized by the highest value of critical pressure compared to others [12]. The magnetic circuit is illustrated by the magnetic field lines (pos. 9). Air is the medium being sealed in the test chamber (pos. 2). The main parameter of the seal is the height of the gap (z) and the nominal diameter of the (D_n) – Fig. 2.

In order to investigate the reseal instability mechanism, magnetic field inhomogeneity was created. This was a result of the different position of the pole (pos. 3a) relative to the seal stage and was carried out by tightening the screws (pos. 7). The distance (e) could be changed in the range 0-0.05 mm – Fig. 2(b).

3. The Reseal Mechanism

The leak mechanism caused by the critical pressure (p_{cr}) is likely to be as shown in Fig. 3. In the case of no. 1 pressure $p_1 = p_2$. The shape of the free surface of the

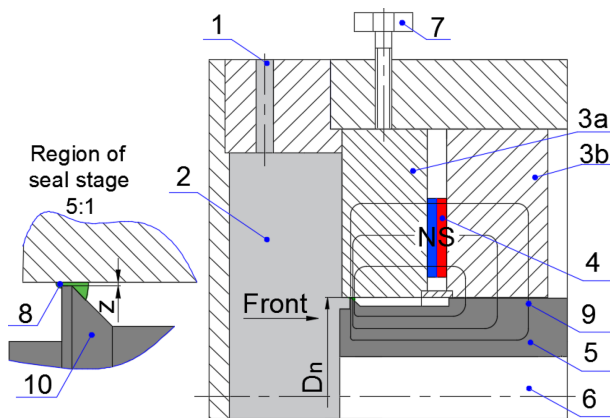

Fig. 1. (Color online) Elements of the magnetic fluid seal.

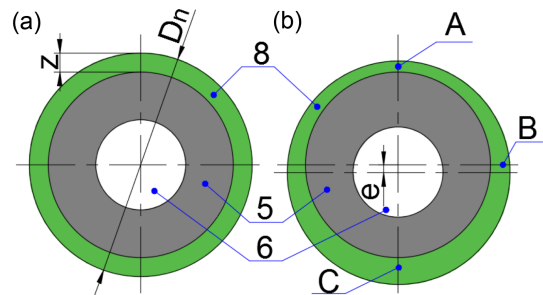

Fig. 2. (Color online) Front view on the ferrofluid ring: (a) no relative displacement, (b) displacement between the pole piece and the seal stage.

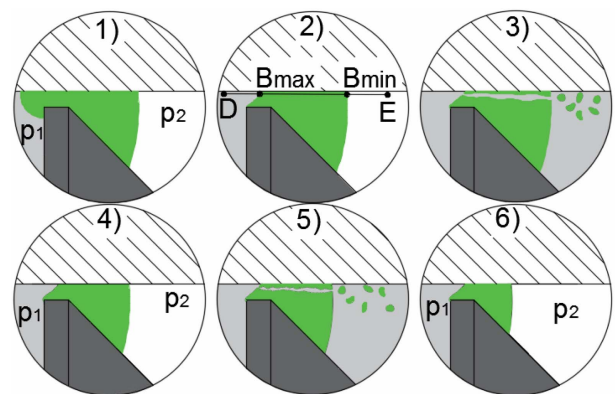

Fig. 3. (Color online) The mechanism of ferrofluid ring instability.

ferrofluid is a result of constant magnetic induction [13, 14]. We assume that the shaft is not rotating and surface tension forces are not taken into account. The increase in the pressure p_1 causes the fluid to move in an axial direction. In the case of $p_1 = p_{cr}$, a channel is formed and a leak occurs (case 3). This is accompanied by a loss of some ferrofluid volume. When the pressure p_1 drops below the critical value, this leads to closure of the channel (case 4). Further p_1 pressure increases to the p_{cr} value would repeat this phenomenon (case 5). Ferrofluid is able to close the ring (case 6) if the pressure p_1 decreases again and there is suitable fluid volume. The critical pressure value can be calculated by using Bernoulli's equation [2]:

$$p + \frac{1}{2} \rho v^2 + \rho gh - \mu_0 \bar{M} H = const. \tag{1}$$

Where:

- p : composite pressure in ferrofluid
- ρ : ferrofluid density
- g : gravitational acceleration
- M : magnetization of ferrofluid
- μ_0 : vacuum magnetic permeability
- v : velocity

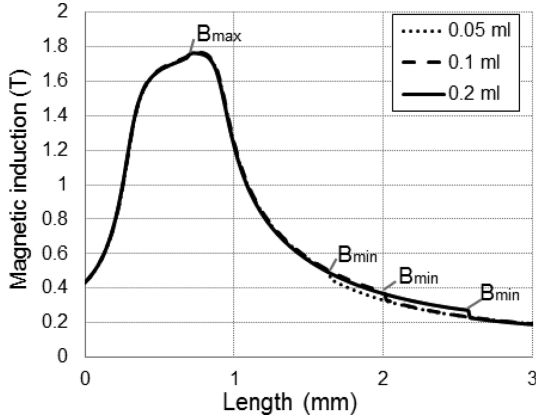

Fig. 4. Distribution of magnetic induction in a seal for different ferrofluid volume.

H : magnetic field intensity

h : reference height

Ferrofluid in the seal in most cases is in a state of magnetic saturation. Also assuming that we neglect the influence of the gravitational field and surface tension and considering the case of a static seal ($v = 0$ m/s) equation (1) takes the form:

$$\Delta p_{cr} = \mu_0 (M_S \cdot H_{max} - M_S \cdot H_{min}) = M_S \cdot \Delta B_{max-min} \quad (2)$$

Where:

M_S : magnetic saturation

p_{cr} : critical pressure

B : magnetic induction

An example of the distribution of magnetic induction for the points between D and E obtained by simulation is shown in Fig. 4. The value of critical pressure is determined mainly by the saturation magnetization of the ferrofluid and the magnetic induction difference between the B_{max} and B_{min} points [15]. The higher the difference, the more critical pressure increases. In the case of the reseal mechanism, critical pressure decreases in subsequent cycles because lower volume means that the magnetic induction difference between B_{max} and B_{min} decreases - Fig. 4.

4. Pressure Oscillation Mechanism

The scheme of the test stand elements is shown in Fig. 5(a). The air under pressure (p_{gc}) flows from a gas cylinder (pos. 1) by a flow valve (pos. 2) to the test chamber (pos. 3). The magnetic fluid seal acts as a switch (pos. 4). It remains open only when the pressure in the test chamber (p_{tc}) is equal or greater than the critical pressure of the seal (p_{cr}). In this case, the air gets into the

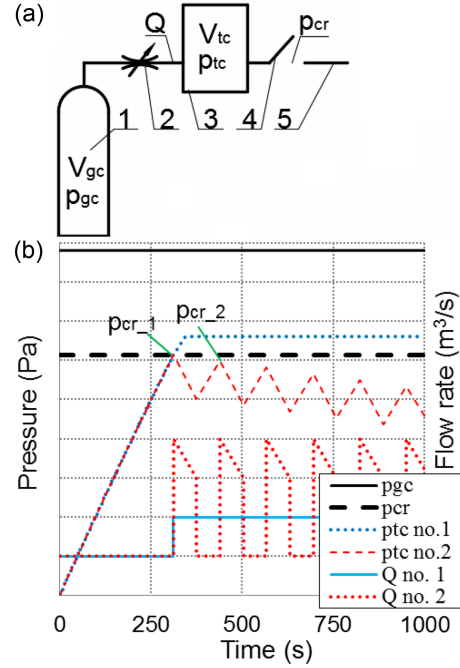

Fig. 5. (Color online) (a) The scheme of the test stand elements, (b) pressure and flow rate change in ideal cases.

atmosphere (pos 5). The other important parameters of the system are the volume of the gas cylinder (V_{gc}), the air flow rate (Q) and the volume of the test chamber (V_{tc}).

Parameters of the magnetic fluid seal and the test stand have an impact on the occurrence of pressure oscillations in the test chamber. Pressure oscillations in the test chamber will not occur if the leak through the seal is low. In the case of pressure (p_{tc} no. 1) and air flow rate (Q no. 1), this is presented as an ideal case in Fig. 5b. In a situation where the pressure in the test chamber rises above the critical value (p_{cr}), it remains at this level and this leads to the seal not rebuilding because inflow from the gas cylinder is greater than the leakage flow. Pressure oscillations in the test chamber will occur if the leak through the seal is large. When the pressure in the test chamber (p_{tc} no. 2) reaches the value p_{cr_1} , it starts to drop and at a certain value the seal rebuilds - Fig. 5(b). Then the pressure in the test chamber increases again until the next critical value p_{cr_2} occurs. In this case, however, it will have a smaller value. The cycle of destruction and rebuild is repeated.

5. Research Methodology and Test Parameters

Four ferrofluids produced by the Ferrotech Company were selected. Their properties are shown in Table 1 and they differ in the values of saturation magnetization and

Table 1. The properties of the fluids used in the tests.

No.	Ferrofluid name	Saturation magnetization M_s , kA/m	Density g/ml	Viscosity mPas (25 °C)
1	APGW05	30.66	1.299	517
2	APGW10	30.82	1.316	1042
3	APGS21	17.16	1.138	500
4	APG1134	17.16	1.058	982

dynamic viscosity. The viscosity values are given in the absence of a magnetic field. Fluids no. 1 and no. 2 have similar values of saturation magnetization, but different dynamic viscosity. There is a similar case between fluids no. 3 and no. 4. Air at the pressure of 0.2 MPa from the gas cylinder and by the flow valve supplies the test chamber with a rate of about 100 Pa/s through the inlet (pos. 1, Fig. 1). During the research, pressure change in the test chamber was measured. The measurements were carried out at the temperature of 25 °C. Each test was preceded by setting the proper eccentricity (e). Measurement of this eccentricity was made with a feeler gauge. The study was performed for a nominal diameter of the magnetic fluid seal $D_n = 50$ mm. Gap height was $z = 0.1$ mm. The source of the magnetic field was a neodymium magnet with coercivity of $H_{bc} = 950$ kA/m and remanence $B_r = 1.21$ T. In experimental studies, the magnet volume was 4.4 cm³, 8.8 cm³, or 17.7 cm³. Pressure was measured using a sensor with a range of 0.1 MPa and accuracy class of 0.25. Measurement data were recorded every 0.25 s on a computer using the LabView program and NI USB-6221 device. The test chamber volume was 0.5 dm³ and gas cylinder volume 6 dm³.

6. Magnetic Field Distribution

Numerical simulations were performed to determine the magnetic field in the seal [16] and [17]. Analyses of magnetic circuits were made by using the finite element method. Currently, this is the only method to determine this distribution, but it is convenient and provides visualization and comprehensive results [18]. The ANSYS 14.5 program was used for this purpose. In order to take into account the displacement of the pole piece, seal geometry was modeled in three dimensions, like in [19]. Simulation studies were performed for eccentricity in the range 0-0.05 mm. Analyses were performed for two magnet volumes: 8.8 cm³ and 30.9 cm³. The magnetic induction distribution on the seal stage for $z = 0.1$ mm, with a magnet volume of 8.8 cm³, is shown in Fig. 6. Results are presented for $e = 0$ mm and $e = 0.05$ mm. For $e = 0.05$

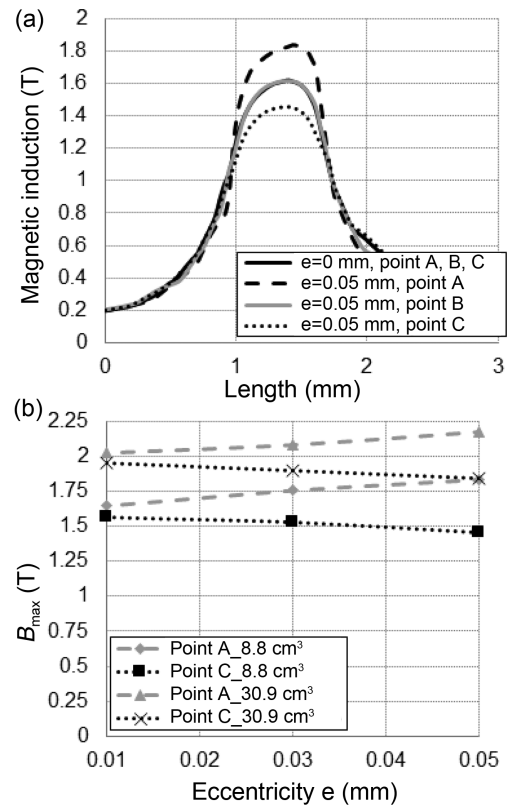
**Fig. 6.** Simulation results: (a) distribution of magnetic induction in the seal, (b) different magnet volume.

mm, three points, A, B and C on the circumference marked in Fig. 2(b), are taken into account. Displacement of the pole piece means that B_{max} increases by about 0.21 T where the seal gap is the smallest - point A. B_{max} decreases by about 0.16 T where the seal gap is the largest - point C.

An increase in eccentricity results in an increase in the magnetic induction at point A and a decrease at point C in the case of B_{max} . This is shown in Fig. 6(b). A larger volume of the magnet means that B_{max} has higher values, but that the difference between points A and C is higher for 8.8 cm³ than for 30.9 cm³. This may suggest that, when the magnetic saturation of the magnetic fluid region is increasing, eccentricity (higher gap z) has less impact on the seal critical pressure reduction when compared to $e = 0$ mm.

7. Experiment Results

In the first step, four ferrofluids were taken into account - Fig. 7. On the graph, the time when the pressure is linearly increasing in the test chamber is not shown. The ferrofluid volume applied on the seal stage was 0.1 ml. The volume of the magnet was 8.8 cm³. In the case where

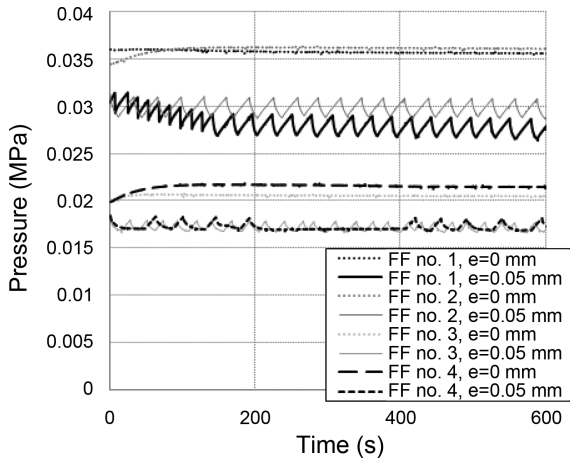

Fig. 7. The pressure change over time in a test chamber for different ferrofluids and two eccentricities $e = 0$ and $e = 0.05$ mm.

there is no eccentricity, even though there is a constant supply of air from the gas cylinder, the pressure stabilizes at a constant level or a little decline is observed. In this case, there is a permanent channel, like in Fig. 3, pos. 3, formed in the liquid ring through which air leaves the test chamber. After a time of 100 s for the eccentricity $e = 0$ mm, higher pressure values are observed for fluids with higher dynamic viscosity (fluids nos. 2 and 4). Eccentricity means that the pressure takes the form of a periodic function. In the case of fluids no. 1 and no. 2 (for time 100-600 s), the peak-to-peak value is approximately 2 kPa and the oscillation frequency is about 0.05 Hz. For fluids no. 3 and no. 4, pressure change is more unpredictable. This can especially be observed for fluid no. 4 in the time range 205-400 s, where the curve has a flat shape. In this period, air constantly leaves the test chamber through a seal. The peak-to-peak values are almost two times smaller for fluids no. 3 and no. 4 compared to fluids no. 1 and no. 2.

The impact of the eccentricity on reseal instability is shown in Fig. 8. Fluid no. 1 and the magnet volume of 8.8 cm^3 were selected. The ferrofluid volume applied on the seal stage was 0.1 ml. In the time interval 0-150 s, the periodic function has a shape similar to a sawtooth and the pressure has a downward trend. In the time interval 150-600 s, the periodic function has a shape similar to a triangle. A downward trend is observed, but with a smaller rate. Higher pressure values are observed for smaller eccentricity. This is probably because the eccentricity for the leak channel is greater due to the decrease in magnetic induction. This statement is partly confirmed by Fig. 9, which shows the relationship between the critical pressure p_{cr_1} in the case of magnetic field simulation and the

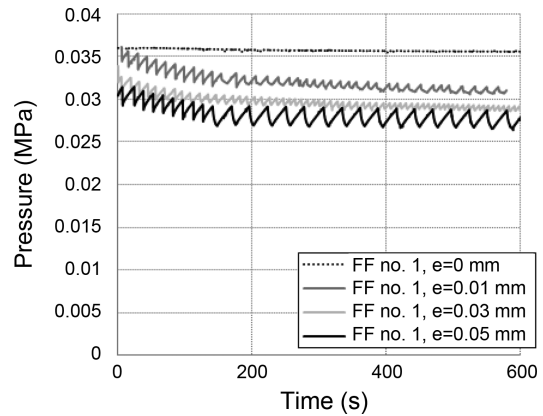

Fig. 8. The pressure change over time in a test chamber for different eccentricity and ferrofluid no. 1.

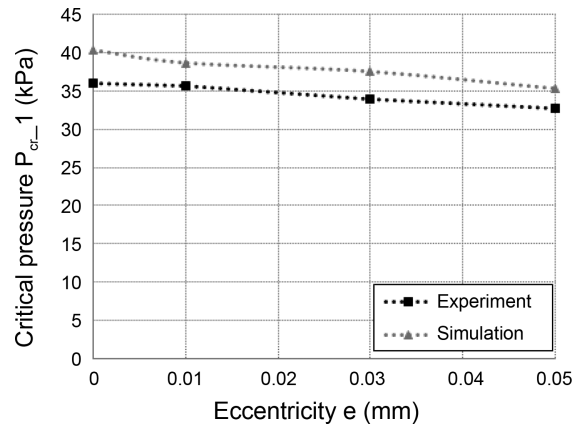

Fig. 9. The critical pressure p_{cr_1} of the seal obtained on the basis of the simulation and experimental results.

experiments. The critical pressure values in the simulation were obtained from equation (2) and for point C – Fig. 2b. The calculated values of critical pressure are higher than those obtained by experiments on average by 10 %. The eccentricity $e = 0.05$ mm reduces critical pressure

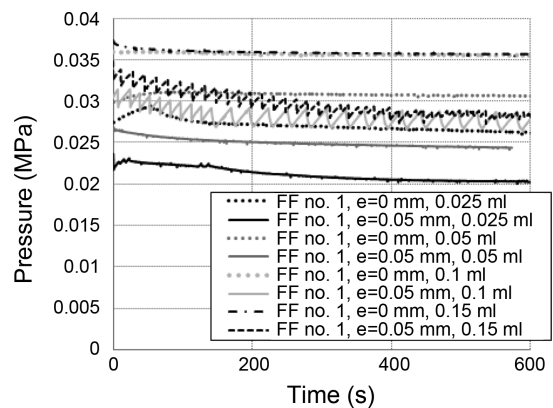

Fig. 10. The pressure change over time in a test chamber for different ferrofluid no. 1 volume.

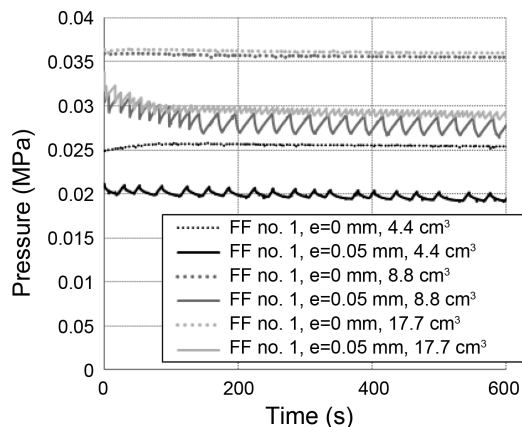

Fig. 11. The pressure change over time in a test chamber for different magnet volumes for fluid no. 1.

p_{cr_1} by about 8 %.

In Fig. 10, the influence of the ferrofluid volume applied on the seal stage on the pressure changes is shown. Fluid no. 1 and the magnet volume of 8.8 cm^3 were selected. The increase in the volume means that the pressure takes a higher value. Meanwhile, for the volumes 0.1 ml and 0.15 ml for $e = 0 \text{ mm}$, pressure change is very similar. When $e = 0.05 \text{ mm}$, differences between the volumes 0.1 ml and 0.15 ml are observed. For 0.15 ml, the pressure oscillations have the shape of a sawtooth and, over time, the peak-to-peak value and period of the pressure oscillations decrease. Pressure oscillations are not observed for a volume less than 0.05 ml.

In Fig. 11, the influence of the magnetic field on the pressure changes is shown. Fluid no. 1 was selected. The volume of the ferrofluid applied on the seal stage was 0.1 ml. Studies were carried out for three magnet volumes: 4.4 cm^3 , which corresponds to ($B_{\max} = 1.42 \text{ T}$), 8.8 cm^3 , which corresponds to ($B_{\max} = 1.77 \text{ T}$) and 17.7 cm^3 , which corresponds to ($B_{\max} = 1.94 \text{ T}$). These values were obtained by numerical analyses using the finite element method for $e = 0 \text{ mm}$. The increase in magnetic induction reduces the peak-to-peak value and the period of the pressure oscillations. This may be caused by the fact that the seal rebuilds faster at a higher magnetic field. When magnet volume is 4.4 cm^3 and $e = 0.05 \text{ mm}$, the shape of the oscillations is different than for other research. Probably the reason in this case is that when pressure reaches the critical value, it takes more time to rebuild the liquid ring.

In Fig. 12, the influence of the seal linear velocity on the pressure changes is shown. Fluid no. 1 and the magnet volume of 8.8 cm^3 were selected. The ferrofluid volume applied on the seal stage was 0.1 ml. Speed reduces the peak-to-peak value and the period of the pressure oscillations. In the case of dynamic tests, it should be

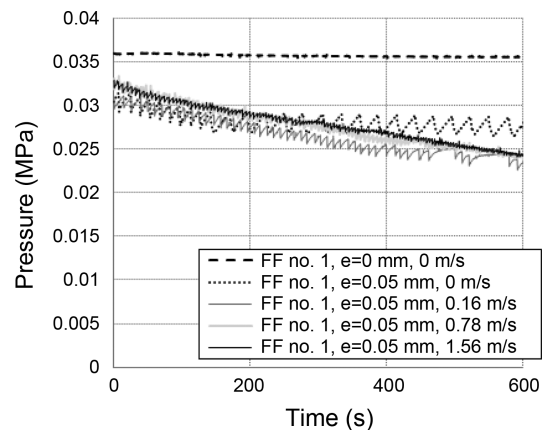

Fig. 12. The pressure change over time in a test chamber for different linear speeds for fluid no. 1.

noted that the result of the experiment is additionally influenced by the vibration of the rotating elements and the seal radial runout. The shaft-bearing combination in the test chamber consisted of two single-row angular contact ball bearings and one cylindrical roller bearing. This bearing system and manufacturing inaccuracies meant that a gap between the pole piece and seal stage during shaft rotation additionally changes by about 0.02 mm from nominal eccentricity.

8. Conclusion

(1) The study showed that, in the magnetic fluid, seal instability involving the cyclic destruction and rebuilding of the liquid ring may occur. A necessary condition in the case of the critical pressure value is a leak channel large enough to allow the appropriate air volume to leave the test chamber. This should cause a sufficiently large pressure drop in the test chamber so that the seal can be rebuilt. In the case of the conducted tests, the increase in the leak channel was achieved through eccentricity, which caused a non-homogeneous magnetic field in the seal and a lower magnetic induction value in the ferrofluid where the largest seal gap will be. As research has shown, the provision of these conditions does not always cause pressure oscillations to be present, because this phenomenon depends on many parameters, mainly on the rate of pressure increase in the test chamber and magnetic fluid seal parameters.

(2) Many factors have an influence on the pressure oscillation shape. One of them is the ferrofluid volume. When there is not enough ferrofluid, the seal can not rebuild itself and a constant pressure drop is observed. Most repetitive oscillations were obtained for fluids with higher saturation magnetization (fluids no. 1 and no. 2)

and a volume of 0.1 ml. An eccentricity decrease reduces the peak-to-peak value of the pressure oscillations but increases their frequency. This trend is also noticeable when the linear velocity and magnetic induction increase.

(3) In the future, this phenomenon can find different technical applications. Measurements of the pressure oscillations can be used as a diagnostic signal to verify whether items are made according to technical documentation or are properly assembled. Studies have shown that it is possible to determine the eccentricity of about 0.01 mm. Measurements could be based on the peak-to-peak value of the pressure oscillations. The period of the pressure oscillation is not a good indicator of the displacement, since it is characterized by greater volatility than the peak-to-peak value.

References

- [1] J. Hu, M. Zhao, L. Wang, J. Zou, and Y. Li, *J. Magn.* **22**, 286 (2017).
- [2] Rosensweig, R. E., *Ferrohydrodynamics*, Dover Publications, New York (2002).
- [3] B. Abou, J. Eduardo, W. Roux, and S. Roux, *J. Fluid Mech.* **416**, 217 (2000).
- [4] C.-R. Benoit, *Environ. Fluid Mech.* **5**, 507 (2006).
- [5] Y. Mitamura, S. Arioka, K. Sakota, and M. Azegami, *Journal of Physics: Condensed Matter* **20**, 204 (2008).
- [6] M. Zahn, *Journal of Nanoparticle Research* **3**, 73 (2001).
- [7] Z. Meng, Z. Jibin, and H. Jianhui, *J. Magn. Magn. Mater.* **303**, 428 (2006).
- [8] J. Ji, F. Xing, J. Du, and N. Shi, *International Journal of Control and Automation* **9**, 79 (2016).
- [9] F. F. Xing, D. C. Li, and X. L. Yang, *Key Engineering Materials* **492**, 283 (2012).
- [10] W. Zhongzhong, D. Li, and Z. Jing, *J. Magn.* **22**, 299 (2017).
- [11] S. Taketomi and S. Chikazumi, *Magnetic fluids: fundamental and application*, NIKKAN KOGYO Publication Production, Tokyo (1988).
- [12] F. Xing, D. Li, and W. Yang, *Advanced Materials Research* **146**, 1278 (2010).
- [13] P. G. Soo and P. S. Ho, *IEEE Trans. Magn.* **38**, 957 (2002).
- [14] R. Ravaut, G. Lemarquand, and V. Lemarquand, *Tribology International* **43**, 76 (2010).
- [15] D. Li, H. Xu, X. He, and H. Lan, *J. Magn. Magn. Mater.* **289**, 419 (2005).
- [16] W. Horak and M. Szczęch, *IEEE Trans. Magn.* **53**, 1 (2017).
- [17] M. Zhao, J.-B. Zou, and Y.-X. Xu, *Journal of China University of Mining and Technology* **16**, 53 (2006).
- [18] P. Gas and E. Kurgan, *IEEE Xplore* **8008997**, 1 (2013).
- [19] B. K. Sreedhar, R. Nirmal Kumar, and P. Sharma, *Nuclear Engineering and Design*. **265**, 1166 (2013).